



P.O. Box 22326
Lincoln, NE 68542

PF: 402/421-9464 | WEBSITE: www.sitescapesonline.com
FX: 402/421-9479 | E-MAIL: info@sitescapesonline.com

INCH TOLERANCES U.O.S.

THE INFORMATION CONTAINED IN THIS DRAWING IS THE SOLE PROPERTY OF SITESCAPES, INC. ANY REPRODUCTION IN PART OR AS A WHOLE WITHOUT THE WRITTEN PERMISSION OF SITESCAPES, INC. IS PROHIBITED.

TITLE *AVONDALE
TABLE & BENCHES*

PRODUCT NO.
AV6-4460-RP

FRACTION-- $\pm 1/16"$
ANG----- $\pm 1^\circ$

*Available in powder coat and DuraCoat finishes

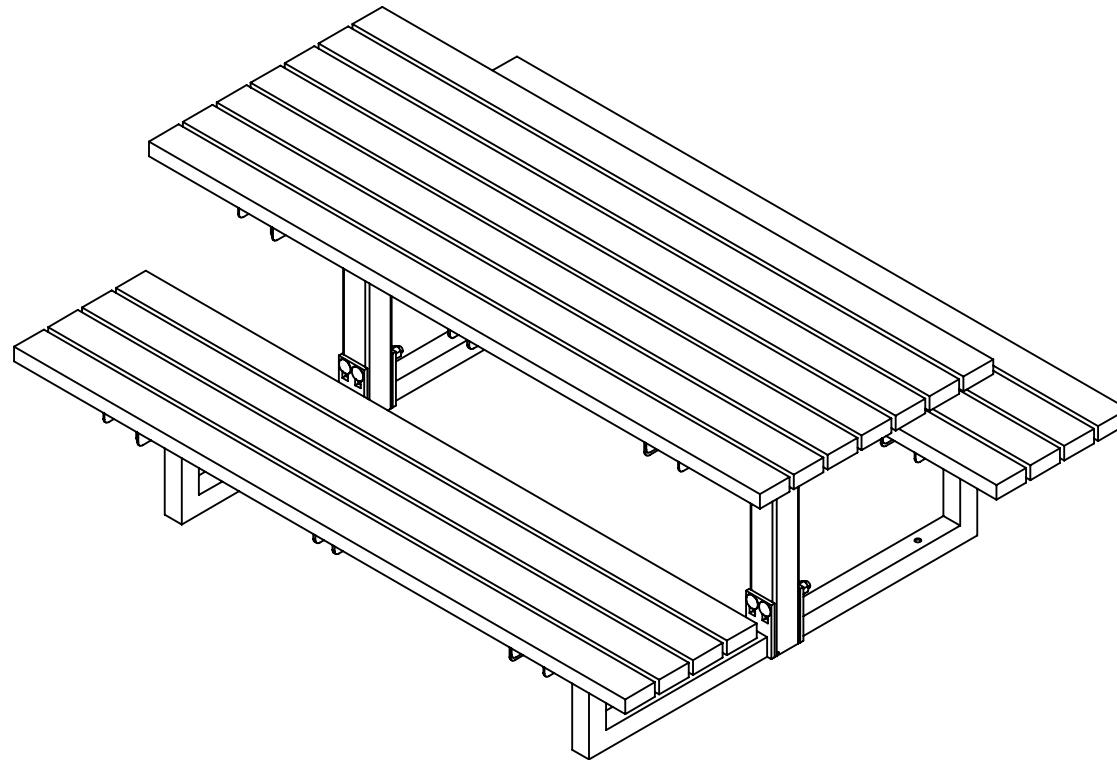



P.O. Box 22326
Lincoln, NE 68542

PF: 402/421-9464
FX: 402/421-9479

WEBSITE: www.sitescapesonline.com
E-MAIL: info@sitescapesonline.com

TITLE *AVONDALE
TABLE & BENCHES*

PRODUCT NO.
AV6-4460-RP

INCH TOLERANCES U.O.S.
FRACTION-- $\pm 1/16"$
ANG----- $\pm 1^\circ$

THE INFORMATION CONTAINED IN THIS DRAWING IS THE SOLE PROPERTY OF SITESCAPES, INC. ANY REPRODUCTION IN PART OR AS A WHOLE WITHOUT THE WRITTEN PERMISSION OF SITESCAPES, INC. IS PROHIBITED.

*Available in powder coat and DuraCoat finishes

MATERIALS LIST:

- (1) Seat Slats - 2" x 4" Nominal Recycled Plastic
- (2) Table Tube - 3" Sq. x 1/8" Wall Steel Tubing
- (3) Seat Tube - 2" Sq. x 1/8" Wall Steel Tubing
- (4) Support Angles - 10 Gauge Steel Plate
- (5) Support Channels - 1/4" Steel Plate
- (6) Support Pipe - ϕ 1" Sch. 40 Steel Pipe
- (7) Mounted with (4) ϕ 1/2" Stainless Steel Anchor Bolts (Customer Supplied)

